



Message from the Headteacher

I am pleased to present our first official newsletter of the year, offering a comprehensive overview of recent developments. From curriculum updates to essential information regarding safeguarding, SEND and council initiatives, there's something for everyone. We understand that everyone has specific interests, so please feel free to select the sections that are most relevant to you. We hope you enjoy looking through this expanded newsletter and learning about all the wonderful things happening in school.

We have a selection of photographs showcasing the exceptional work our pupils have been undertaking in each year group, as well as images of our newly installed playground markings. These additions have given the playground a lift and provided our children with even more opportunities for creative play.

In our assemblies this week we explored the fascinating language of the half-term: Ga. You can learn more about it in our special feature. We also hosted an exciting celebration assembly, with highlights available on page two of this newsletter. Additionally, Mrs Thorlby gave an inspiring talk about the International Day of Peace, highlighting its strong connection to respect, tolerance and the importance of positive attitudes and behaviour.

On Tuesday evening, our PTA had their first meeting of the year. I would like to extend a warm welcome to our new members. Please stay informed about upcoming PTA events and consider joining us if you are interested in contributing further to our school community.

Office Messages

- A polite reminder for parents/carers of Y6 children - please give your consent, via ParentPay, for your child to take part in the visit to Endcliffe Park on Tuesday 24th September.
- We have a growing amount of lost property in school. We do try our best to reunite any lost items, however this can be a difficult/time consuming task. To help us, we politely ask that you label your child's clothing clearly with their full name and class. Thank you.

Key Dates

24th September	Y6 Trip to Encliffe Park
28th September	Cross Country Race 1 High Hazell's Park 8.30am - 12.15pm
October	Black History Month
3rd October	Y3 visit to Creswell Crags
3rd October	Y5/Y6 Tag Rugby Handsworth Grange
4th October	Y5 visit to Jorvik
8th October	Y3/Y4 Reading Workshop, 5.30pm
9th October	Y5/Y6 Maths Workshop, 5.30pm
10th October	Hello Yellow Day Mental health awareness/fundraising
11th October	Y5 Viking Day in school
14th - 24th October	Y6 Bikeability
w/b 14th October	Y3 SEND Review Meetings
15th October	Y5 Viking Assembly 2.45pm
18th October	SEND Family Communication Workshop 9am - 10.30am
w/b 21st October	Y6 SEND Review Meetings
23rd & 24th October	Parent/Carer Evenings (10 min appointments)

This Week's Awards

Achievements Outside School



- * Well done to Bella C who gained a Grade 4 in violin!
- * We have a large number of children who play in the U9 and U11 Hallam Cricket teams. On Sunday 15th September, the children were invited to a special awards ceremony to celebrate another successful year. All children received a medal for their dedication to the club and their achievements were recognised and celebrated in assembly.

It is worth noting that Hallam have a growing girls' team, so if there are any girls interested, Hallam always welcome new players.



The following children achieved an award for TTRS this week:

Y4JH - Alex 4NH - Henry

Y5KL - Harvey

Y6JC - Nathaniel

Y6OS - Lara & Florence

Y6HK - James and Harriet



Focus Value - Respect

Our pupils will be encouraged to:

- Be polite and well-mannered
- Value themselves and other people
- Be respectful, tolerant and caring
- Have mutual respect and tolerance for all, including those with different faiths and beliefs
- Respect our school and its environment take an interest in their community, country and the wider world.

Attendance

Please ensure that your child is on time for school. Children can be brought into the yard from 8:40 am. Learning in school starts at 8:50 am.

Our attendance this week was 97.7%

**LOST MINUTES =
LOST LEARNING!**



Attendance Winners

Congratulations to:

Y3BB, Y5JE and Y6HK

Every week, we will highlight the class in each key phase with the highest attendance.

Our New Playground Markings!

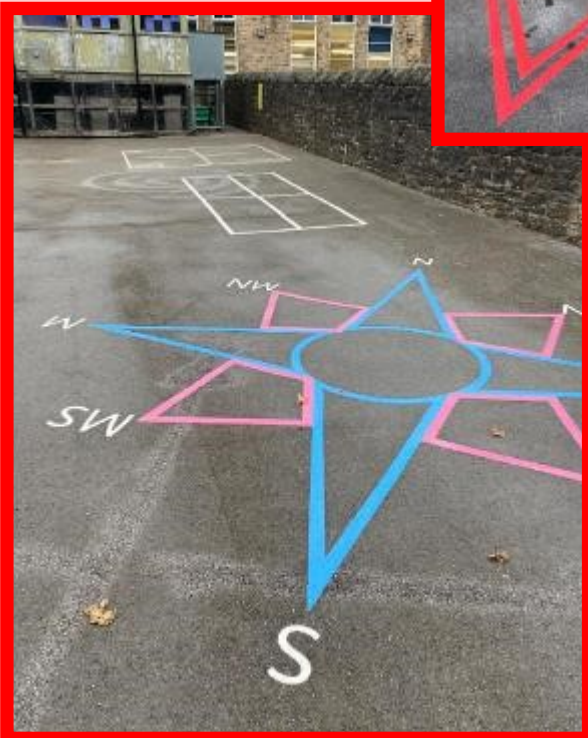

Community

Eco Ambassadors

Welcome to the first Eco Ambassadors bulletin of the year. We are looking forward another year of making Nether Green and the surrounding area more environmentally friendly.



Who are the Eco Ambassadors?

The Eco Ambassadors team at NGJS is made up of two children from each class, including the Integrated Resource, who are passionate about protecting our environment. The team is led by Mrs Wing.

Last year, highlights included: a successful litter campaign to reduce litter in the school grounds, a local area litter pick, a Waste Week campaign to collect and recycle batteries and planting flowers and plants to improve biodiversity. We are looking forward to recruiting our new Eco Ambassadors this year and starting some new and exciting projects. Children will be told how they can put their names forward in assembly.

Eco Dates for your diary

As part of our news updates, the Eco Ambassadors often highlight national initiatives. This month, it is World Cleanup Day on the 20th September and World Rivers Day on the 29th September. Why not collect some litter when you are out and about in the next few weeks? If you do, the Eco Ambassadors would love to hear about it.

Music of the Half Term

Listening to music is fundamental to musical understanding. By learning to listen critically, our children will not only expand their musical horizons but also gain a deeper understanding of how music is constructed and the impact it can have on the listener.

Listening to a broad range of music also helps develop other areas of musical activity, including composing and performing. Therefore, each half term we focus on a 'music of the half term' which is explored through assemblies and further listening opportunities.

This half term we will be focussing on Country music, exploring a wide range of performers from Dolly Parton to Beyoncé!

We will look at the way country music often tells a story and will be linking this to thoughts about transition, as the children settle into their new classes.



Language of the Half Term - Ga

Each term we select a different language for the pupils to learn greetings and basic phrases in. We choose languages which represent our school community. At Nether Green, we feel it is important to give bilingual children the chance to demonstrate their language skills, as well as have opportunity to share details of their family's country and culture. Language of the Half-term also allows monolingual English speakers to encounter and learn to speak a variety of languages.

All teachers embrace the selected language of the half-term and actively encourage the children to say good morning, good afternoon and respond to simple yes/no questions in the given language.

The chosen language for this half-term is Ga.

Ga is one of about eighty languages spoken in Ghana, in and around the capital Accra, by the Ga people. There are also some speakers in Togo, Benin and Western Nigeria.



Community

SEND & Inclusion

SEND and Inclusion

It was lovely to see parents and carers at the coffee morning on Monday. If you were unable to attend but would like to meet Ms Musgrove, please e-mail senco@nethergreen-jun.sheffield.sch.uk and she will be in touch.

The next coffee morning will take place on Thursday 28th November. Please pop the date in your diaries.

SEND Reviews

This term's SEND review dates are listed below. Please note that it is extremely difficult to rearrange reviews so we would be grateful if you could endeavour to make your allotted time. We are able to hold the reviews over Google Meet if it is easier for you – just let Ms Musgrove know. If your child is in Y3 and you saw the SENCO in your last school, you will be invited for an initial meeting. If you think you should have been given an appointment but haven't received one, please e-mail Ms Musgrove. You will receive your allotted time slot approximately 3 weeks before the review date.

Y3 SEND Reviews – Monday 14th and Tuesday 15th October

Y6 SEND Reviews – Monday 21st and Tuesday 22nd October

Y4 SEND Reviews – Tuesday 5th and Wednesday 6th November

Y5 SEND Reviews – Tuesday 12th and Wednesday 13th November

Games and Fidgets

We are always on the hunt for pre-loved games and fidgets. If you are thinking of having a clear-out at home, please consider donating any unwanted games and fidgets to school. We can guarantee that they will be well-loved by our children!

Here are some of the things we collect for our children:

- Fidgets – e.g. spinners, poppits
- Rubix cubes (of any shape or variety)
- 2 player games – e.g. Guess Who, Connect 4, Chess, Draughts
- Jigsaw puzzles – between 100 and 300 pieces
- Construction toys – e.g. Knex, Magnetic Tiles (but not Magnetix due to health and safety reasons)
- Card games – e.g. Snap, Pairs, Uno, Monopoly Deal, Dobble.

If you would like to donate anything, please label it for Ms Musgrove and drop it in to the school office. Thank you.

Safeguarding

Last week in assembly, Mrs Thorlby explained to the children which members of staff make up the school's safeguarding team.

Our Designated Safeguarding Lead (DSL) is Mrs Thorlby.

We have three Deputy Designated Safeguarding Leads (DDSLs): Mr Allen (Head teacher), Ms Bedford (Learning Mentor) and Ms Musgrove (Senco and Assistant Head).

Our designated governor with responsibility for safeguarding is Mr Ian Owen.

We are committed to safeguarding and promoting the welfare of children and young people. We ensure that consistent effective safeguarding procedures are in place to support families, children and staff at this school. Children are encouraged to report anything they feel unsure or uncomfortable about. They know that they can report ANYTHING to ANY adult they feel comfortable with.

If you have concerns about the wellbeing or safety of a child, please contact the office to speak with one of us.

Family Communication Seminar

On Friday 18th October, Nether Green Junior School is hosting a Family Communication Seminar which will be delivered by Sheffield Parent Carer Hub. Parents of children attending Broomhill Infant School, Nether Green Infant School and Nether Green Junior School are warmly welcome to attend.

The seminar will take place from 9:00am – 10:30am and refreshments will be provided.

We would be grateful if you could confirm your attendance by e-mailing senco@nethergreen-jun.sheffield.sch.uk so that we can provide enough refreshments.



Family Communication Seminar

Family Communication Seminar

Friday 18th October 2024

9.00am - 10.30am

**Nether Green Junior School, Fulwood Road, Sheffield, S10
3QA**

A practical seminar for parents and carers of school aged children. Why communication quality matters to your child's education and how to create the best relationship environment for your children. This seminar covers the following helpful topics:

- Setting a good example for your child.
- Home and school environments – how to help your child.
- What we do and say – the difference it can make.
- Learn simple effective skills of being assertive to improve communication in your relationships



For more information please contact Sheffield Parent Hub



0114 2057243



sheffieldparenting@sheffield.gov.uk



Direct message (Sheffield Family Hubs)



Spotlight on the Curriculum - Reading



At Nether Green, our aim is to develop a love of reading and of books. We hope that by ensuring our pupils have time to choose and enjoy a wide variety of books they will become life long readers.

The children have made a fabulous start to the new school year in their reading journey. The library is being well used by all of the classes and the children are really enjoying both the beautiful space and the range of books on offer! The children visit once a week and are able to change their book there. We are happy for the children to take their books home to read.

Our collection of graphic novels and comic style books is, as ever, the most popular section! It is fabulous to see the children sharing and enjoying their books. Sports related books are also flying off the shelves. Our fantasy and adventure sections are always a firm favourite too.

Our class books this term are:

Year 3 Stone Age Tales: The Great Cave and The Great Flood by Terry Deary. This is linked to their project "How did life change for people between the Stone Age to Iron Age?"

Year 4 are reading Who Let the Gods Out? by Maz Evans which links to their project "Who were the Ancient Greeks?"

Year 5 are reading The Riddle of the Runes by Janina Ramirez which links to their project "Raiders or Settlers. How should we remember the Vikings?"

Year 6 are reading Kensuke's Kingdom by Michael Morpurgo, a classic children's novel.

The children will delve deeply into these novels during their reading lessons. Other reading lessons will include full texts linked to the wider curriculum. Pupils will also look at poetry.

Our Y3's have met their Y6 reading buddies! They thoroughly enjoyed their first buddy reading session.



Year 3 have been learning about the Stone Age.

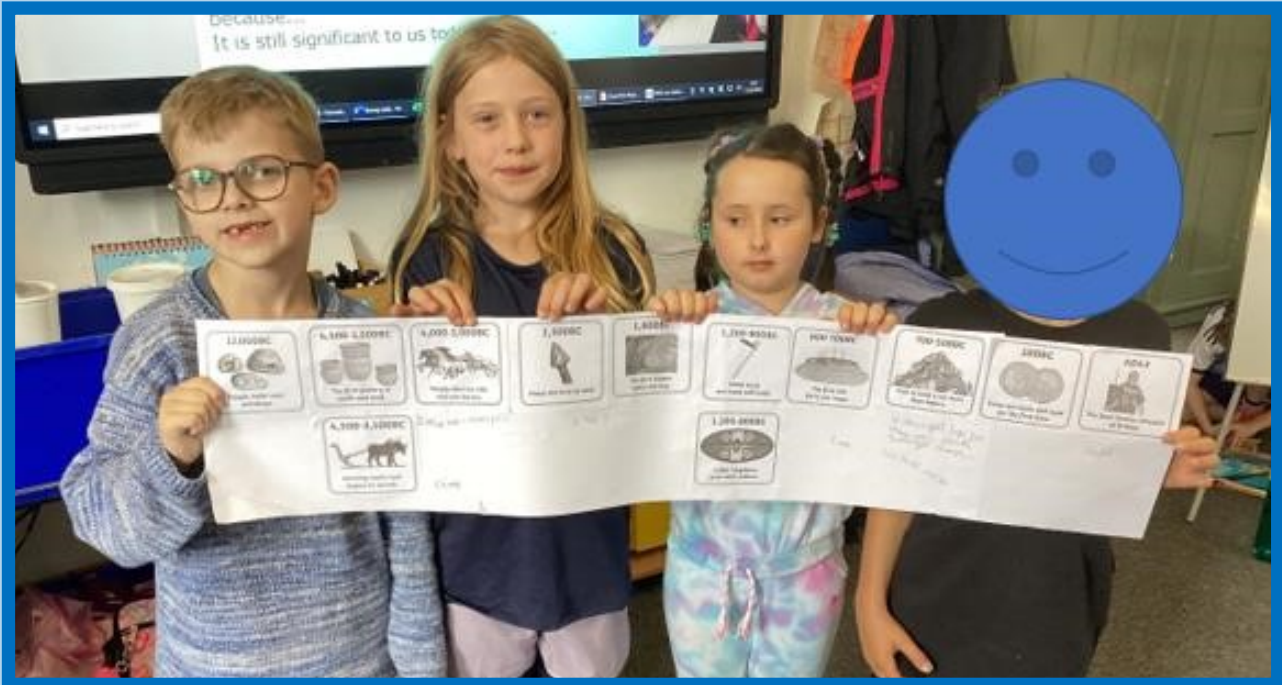

They worked as a team to order the events into chronological order on a timeline.

In English, we have been acting out and re-telling the story of Little Red Riding Hood.

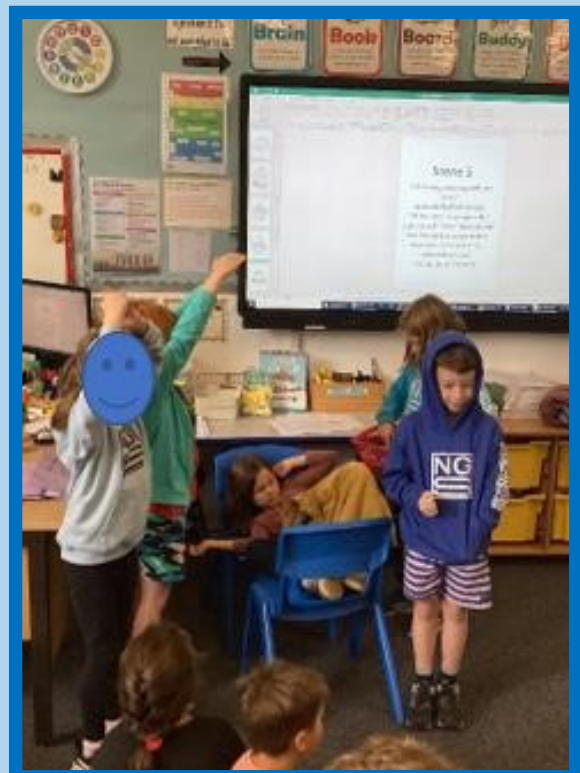

Y4JH had a great time at their swimming lesson at Ponds Forge! They all showed so much respect and resilience.



In Y4, we've thoroughly enjoyed comparing the great cities of Athens and London in our geography lessons. In one of our activities we had to work in pairs to research key information about Athens and London. Then, we created a poster to compare their differences.



Year 5

In Y5 we are working on dance in PE! At the end of our lesson, we danced to 'Dancestar'. It was great fun!



We are also working on The Vikings in English. We are learning to write instructions on the best way to win a Viking battle! We did some research on Chromebooks to make into posters!

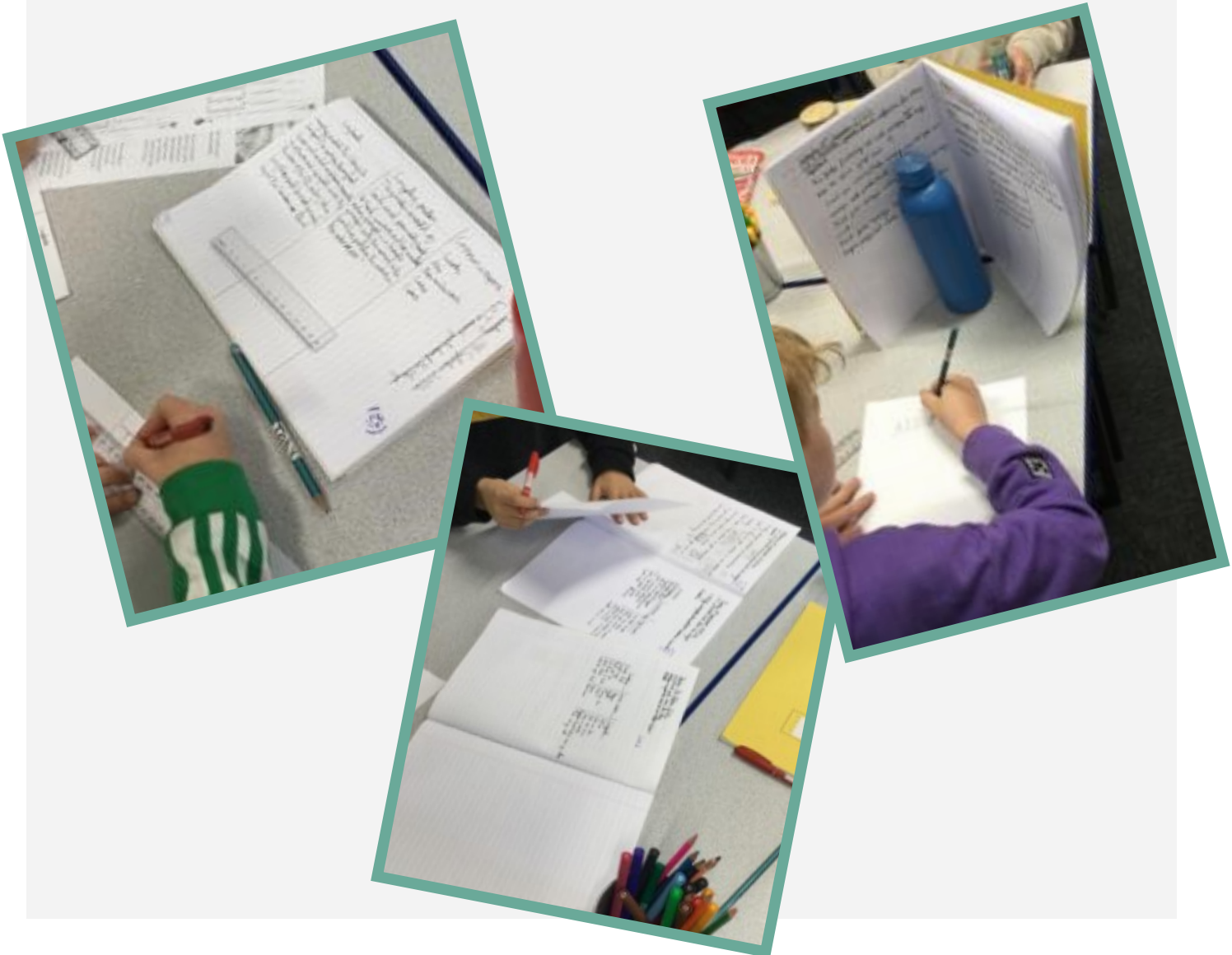

Year 6

As part of their topic on electricity, the Y6 children have been making and testing a variety of circuits, as well as drawing and then using electrical symbols.

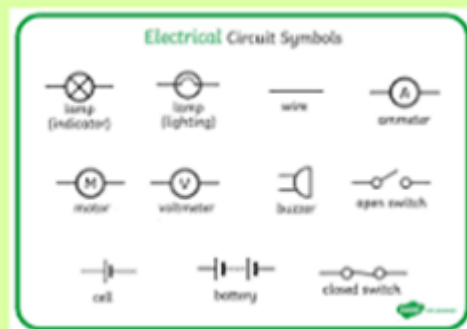

Integrated Resource

Some of the IR children went with a group from school to the Move More Event at the England Institute of Sport.



They had an amazing day joining in with many activities including: table tennis, cycling and fencing.



The children had support from specialist coaches including some who train the GB Paralympic team.



Lunch Menu



PRIMARY MENU WEEK 3	'GREEN EARTH MONDAY'	TUESDAY	WEDNESDAY	THURSDAY	FRIDAY
Main Course PURPLE	Vegetable Chilli & Rice	Farm Assured Pork Sausage Roll with Baked Potato Wedges	Savoury Beef Mince with Yorkshire Pudding, Roast Potatoes & Gravy	Sticky BBQ Chicken & Vegetables with Noodles	Fish Fingers with Chips & Tomato Ketchup
Vegetarian Main Course GREEN	Cheese & Tomato Pizza with Baked Potato Wedges	Cheese & Onion Roll with Baked Potato Wedges	Savoury Vegetable Mince with Yorkshire Pudding, Roast Potatoes & Gravy	Sticky BBQ Quorn & Vegetables with Noodles	Cheese & Tomato Pizza Whirl with Chips & Tomato Ketchup
Street Food RED		Cheesy Bean Pitta Pocket		Cheese & Tomato Melt	
Jacket Potato and Filling YELLOW	Jacket Potato with Cheese or Baked Beans	Jacket Potato with Cheese, Baked Beans or Tuna Mayo	Jacket Potato with Cheese, Baked Beans or Tuna Mayo	Jacket Potato with Cheese, Baked Beans or Tuna Mayo	Jacket Potato with Cheese, Baked Beans or Tuna Mayo
Vegetables	Roasted Peppers & Sweetcorn & Mixed Fresh Salad	Country Mixed Vegetables, Baked Beans & Mixed Fresh Salad	Carrots, Garden Peas & Mixed Fresh Salad	Broccoli, Cauliflower, Carrots & Mixed Fresh Salad	Garden Peas, Baked Beans & Mixed Fresh Salad
Dessert	Baked Apple Sponge with Custard	Tootie Fruity Jelly and Mandarins	Freshly Baked Vanilla Cookie	Zesty Lemon & Blueberry Yoghurt Cake	Homemade Flapjack

Available Daily: Salad Selection, Fresh Bread, Fresh Fruit and Yoghurts



Our desserts meet Public Health England's target for 'free sugar' intake for your child.

Recommended fruit and vegetable portion sizes are calculated using School Food Standards. On average our desserts do not exceed a third of a child's recommended 'free sugar' intake.

ORIENTEERING

THE MIND AND BODY WORKOUT



SATURDAY SERIES SCHOOLS & ADULTS LEAGUE 2024 / 25

2024 / 25 Saturday Series incorporating the SFSS Schools' League

Orienteering is a challenging outdoor adventure sport. The aim is to navigate between control points marked on an orienteering map and decide the best route to complete the course in the quickest time. It does not matter how young, old or fit you are, as you can run, walk or jog the course at your own pace.



These events are specifically aimed to introduce people of all ages to the sport and also incorporate the SFSS schools' league. However all our events have courses suitable for all abilities - see the website for more details. No need to pre-enter: just turn up on the day. Start times from 12.30pm - 3pm.

League Format

Nine events spread over the academic year for pupils from Y3/4 up, with a separate league for adults. The series culminates with a fun event and prize-giving. Dates and venues are listed overleaf. Overall positions for competitors and schools will be calculated from their best 5 results. The events are held on Saturday afternoons. They are run by South Yorkshire Orienteers and courses are open to the general public, so anybody can give it a go!

Registration & Start Procedure

Register on the day between 12.30-2.30pm. Entrants will receive a map with the course printed on and an electronic timing chip. Competitors on each course will start at 1 minute intervals. You are welcome to go individually or in a pair or group. Parents can talk through the course and can shadow (follow) competitors around the course but please let children navigate themselves.

Costs

Children £2. Pupils Y3 & above, whose school is a member of the SFSS, are free.

Adults £5, £4 for club members
Second runs £2 (£1 if paid for 1st run)

Courses

Orienteering courses are graded by colour; this table shows the course pupils should enter to be part of the league. Adults run whichever course they would like and will be allocated points for the adult league.

Course	Year
White	Y3/4, Y5
Yellow	Y6, Y7
Orange	Y8, Y9
Light Green	Y10, Y11
Green / Blue	Y12, Y13

About SYO

South Yorkshire Orienteering club is one of the most successful clubs in the country at both Junior and Senior level. We organise regular orienteering events and training throughout the year. We can also arrange introductory sessions for Running Clubs, Schools, Scouts, Guides, Youth Groups etc.

Sat 21 Sep	Endcliffe Park
Sat 19 Oct	EIS & Olympic Legacy Park
Sat 23 Nov	Shirebrook
Sat 4 Jan	Whirlowbrook Hall
Sat 1 Feb	Norfolk Park
Sat 22 Mar	Bolehills
Sat 26 Apr	Chapelton Park
Sat 7 Jun	Meersbrook Park
Sat 21 Jun	Graves Park

Prize-giving event Millhouses Park 12 Jul

SOUTHYORKSHIREORIENTEERS.ORG.UK

SOUTHYORKSHIREORIENTEERS.ORG.UK



King Edward VII School



Year 5 and Year 6 Open Evening

Tuesday 24 September 2024, 6.00pm - 8.00pm

At King Edward VII Upper School
Glossop Road, S10 2PW

For more information please contact the School's reception
on 0114 266 2518 or email office@kes.sheffield.sch.uk

All prospective students, parents and carers are welcome.



www.kes.sheffield.sch.uk

HIGH STORRS SCHOOL Y6 OPEN EVENING



Thursday 26 September 2024,
5.30-8pm. Find out more here



CHRIST CHURCH
Fulwood

LAST OF THE SUMMER VIBE

SATURDAY 21 SEPTEMBER
1PM - 5PM

EVERYONE IS WELCOME!

**MUSIC | MOCKTAILS | PIZZA
CHILD FRIENDLY STALLS | NAIL ART
BOUNCY CASTLE | LAWN GAMES | AND MORE**

CANTERBURY AVE, SHEFFIELD S10 3RT